

POWER AMP ASS'Y AWH-045

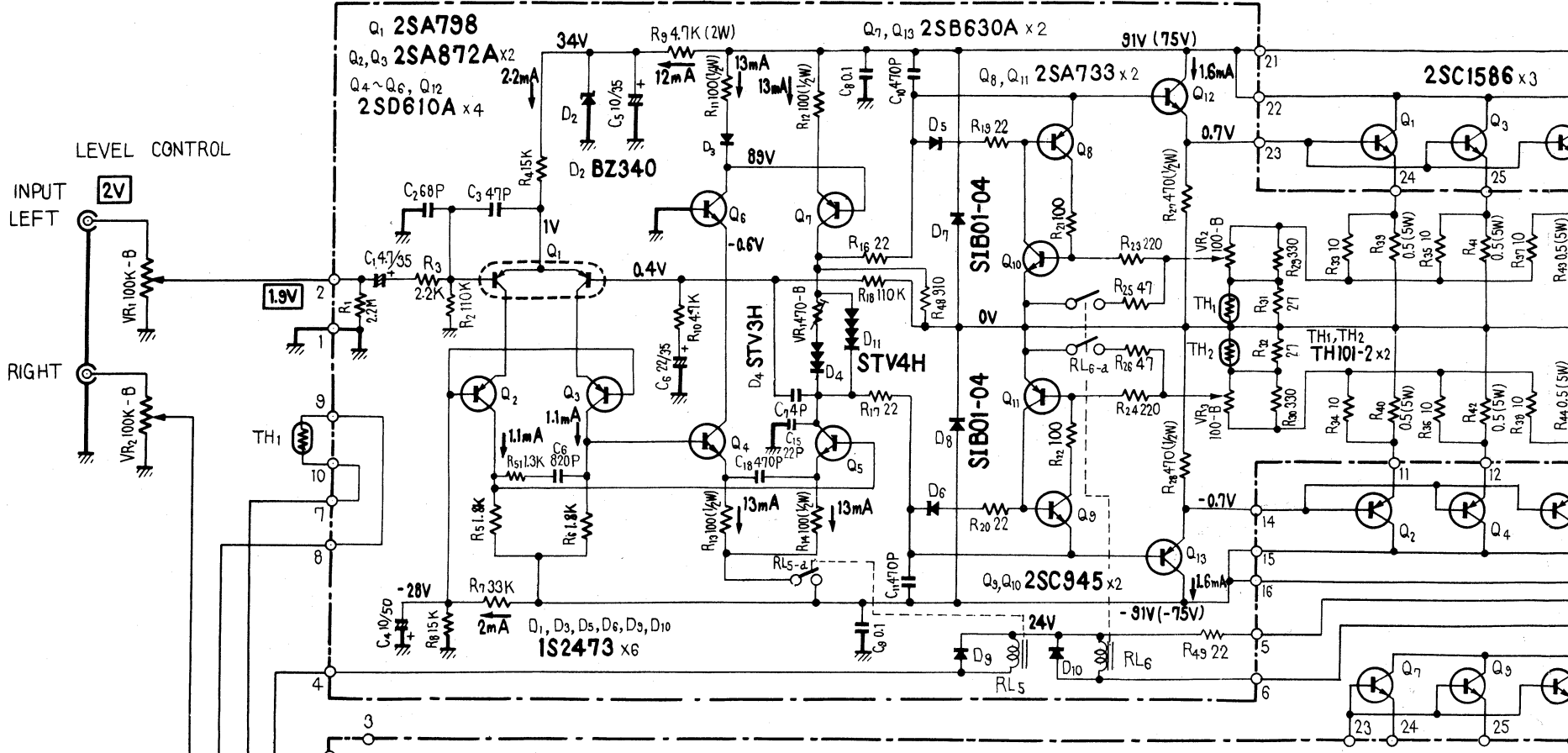

POWER AMP ASS'Y AWH-045

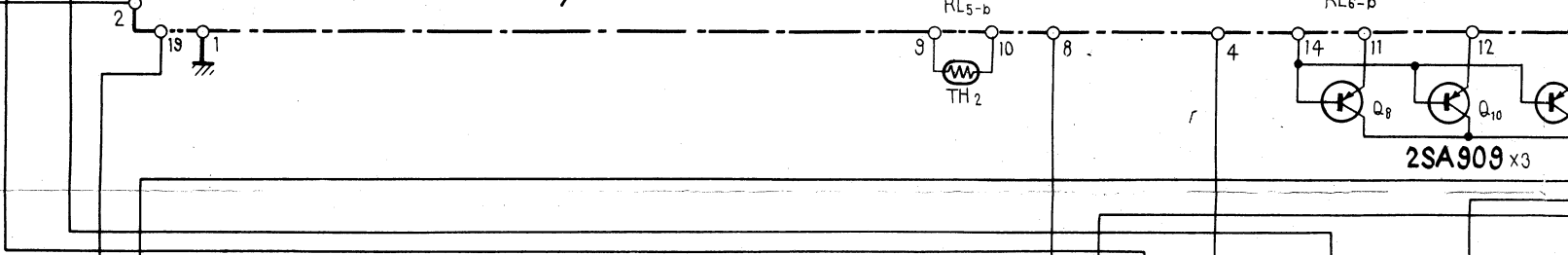

METER AMP ASS'Y AWM-081

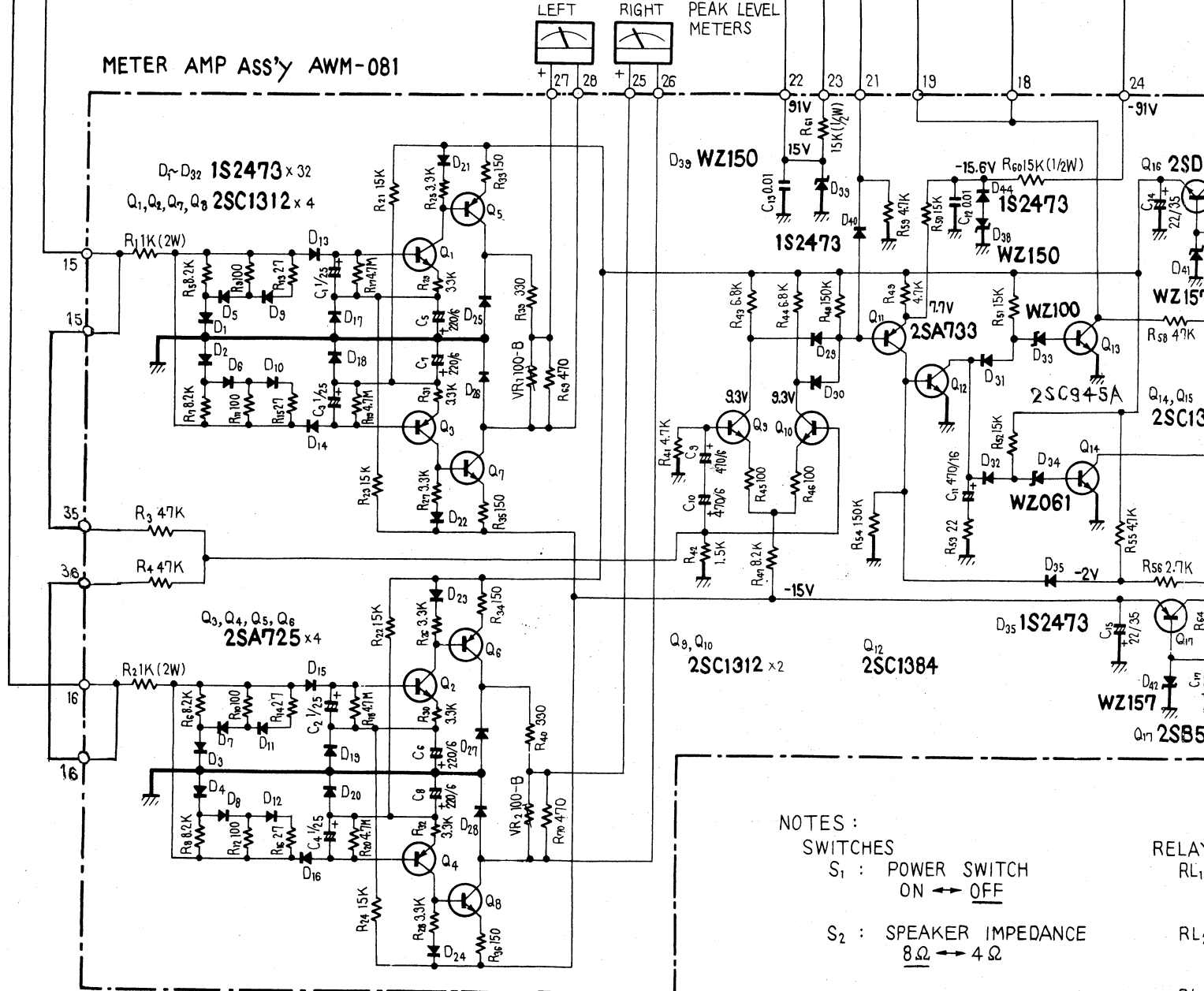

- NOTES:
- SWITCHES
  - S<sub>1</sub> : POWER SWITCH  
ON ↔ OFF
  - S<sub>2</sub> : SPEAKER IMPEDANCE  
8Ω ↔ 4Ω

RELAY  
RL1  
RL2  
RL3  
RL4  
RL5  
RL6

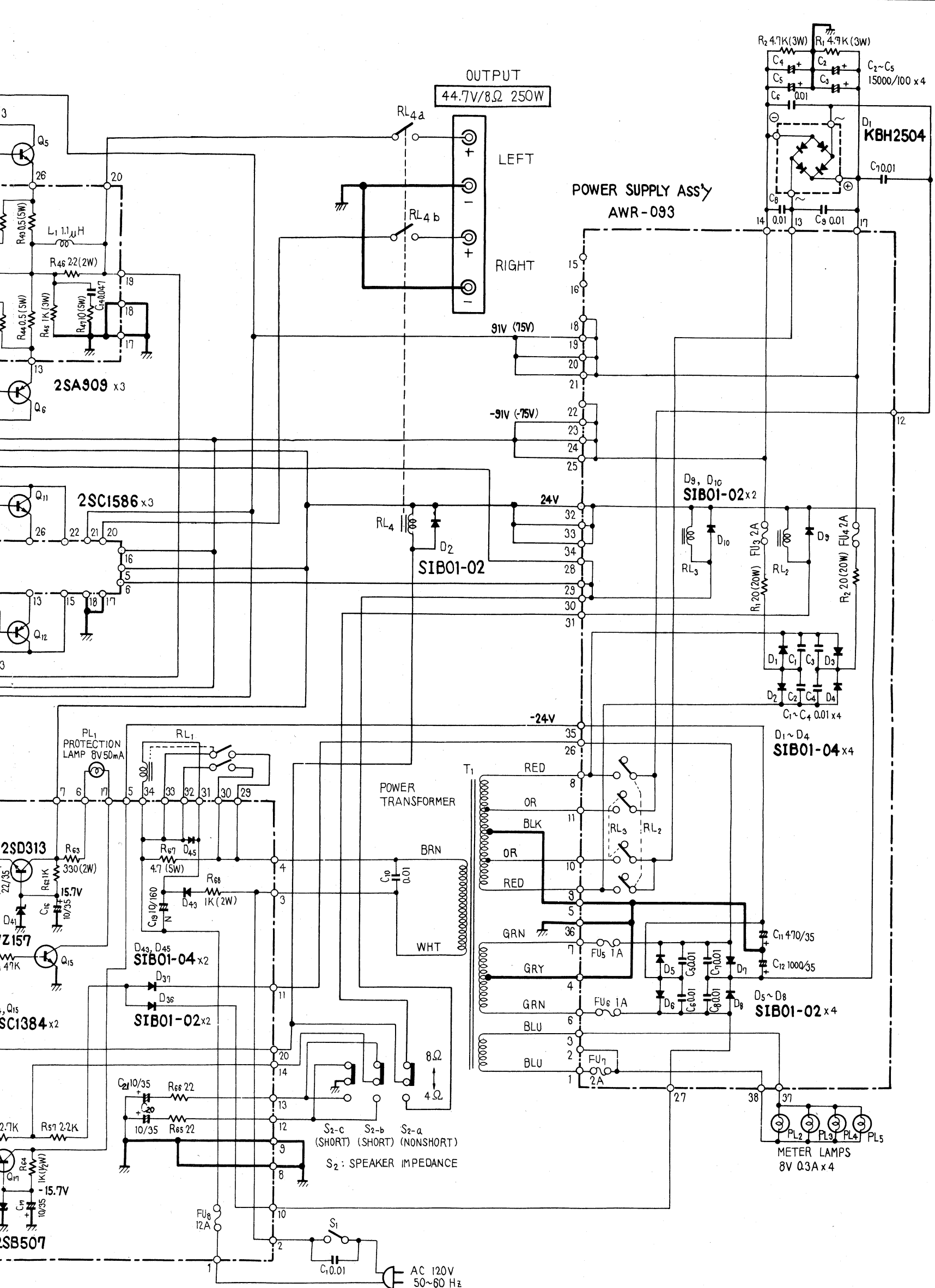

- RELAYS
- RL<sub>1</sub> PRIMARY SURGE CURRENT CONTROL RELAY
  - RL<sub>2,3</sub> SECONDARY SURGE CURRENT CONTROL AND VOLTAGE SELECTOR RELAYS
  - RL<sub>4</sub> OUTPUT CUT-OFF RELAY
  - RL<sub>5</sub> MUTING RELAY

RL<sub>6</sub> CURRENT LIMITOR SENSITIVITY CONTROL RELAY.

- V : SIGNAL VOLTAGE NECESSARY FOR OBTAINING 250W/8Ω OUTPUT POWER (1KHz).
- V : DC VOLTAGE AT NO INPUT SIGNAL.
- ( V ) : DC VOLTAGE AT 250W/8Ω OUTPUT POWER.
- ← mA : DC CURRENT AT NO INPUT SIGNAL.